



□ SINGLE SIDED BAYS

flexible storage space



library  
office  
education  
reference  
retail



 **RICHARDSONS** 6 Collingwood Court  
 MAKING WORKSPACE WORK Riverside Park  
 Middlesbrough TS2 1RP

Tel: 01642 242228 | Fax: 01642 242259  
[www.richardsonsuk.co.uk](http://www.richardsonsuk.co.uk) | [sales@richardsonsuk.co.uk](mailto:sales@richardsonsuk.co.uk)

versatile & stylish

### TECHNIC SHELVING

This versatile shelving system offers a wide range of specialist shelves and accessories to suit your business. Technic shelving can be quickly adapted to meet your changing needs and is quick and easy to construct, saving down time and minimising disturbance.

- **WALL MOUNTED BAYS**  
Available in five heights, see overleaf.



**SHELF PROFILE**  
Technic shelves have been designed with a rolled front face adding strength and allowing for display strips to be inserted.

**SHELF OPTIONS**  
A wide range of shelf options has been made available to suit your needs, all available in three widths, 750, 900 and 1000mm. See pages 6 & 7 for details.

**A STYLISH SYSTEM**  
A stylish system well suited to your environment.

**5 HEIGHT OPTIONS**  
**Wall Bars** are available in five heights 1030, 1380, 1680, 2030 & 2530mm.  
Note: Free standing uprights available in different heights, see opposite.

**SHELF ADJUSTMENT**  
Shelves can be raised or lowered by 25mm increments making this system extremely versatile.

**QUICK BUILD SYSTEM**  
Technic shelving can be adjusted as quickly as it can be built.



### PROBE ACTIVECOAT DEVELOPED IN CONJUNCTION WITH DUPONT

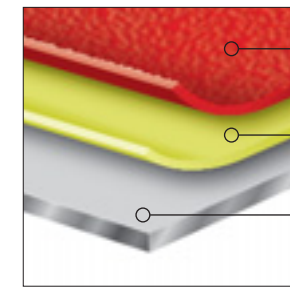

**AC+IVECOAT®**  
The hard wearing anti-bacterial powder coating for the most stringent hygienic environment.

**IRON PHOSPHATE KEY COAT**  
This anti-rust, key coat bonds to the steel in readiness for the final active coating.

**PREPARED STEEL SURFACE**  
Chemical cleaning ensures an ideal surface for further coatings.



*The miracles of science™*



- **SINGLE SIDED BAYS**

### UPRIGHTS

This versatile system includes single & double sided floorstanding uprights, wall mounted & wheel mounted uprights. All uprights allow for quick and easy adjustment of shelves in increments of 25mm.

### 5 HEIGHT OPTIONS

**Free standing** uprights available in five heights 1200, 1500, 1800, 2100 & 2300mm. See pages 6 & 7 for details.  
Note: Wall Bars available in different heights, see opposite.

### REMOVABLE BACKSTOP

These clear plastic backstops can be easily removed if required.

### FEATURES & BENEFITS

- Anti-slip finish on shelves.
- Full range of optional accessories.
- Adjustable feet (except wall & wheel mounted units).
- Elegant and sturdy construction
- A quick and easy to build system
- Available in a wide range of colours
- Vertical support for Books, folders etc



### AVAILABLE COLOURS

All Technic units are powder coated with AC+IVECOAT® exclusive to Probe.



**RICHARDSONS** 6 Collingwood Court  
MAKING WORKSPACE WORK Riverside Park  
Middlesbrough TS2 1RP

Tel: 01642 242228 | Fax: 01642 242259  
www.richardsonsuk.co.uk | sales@richardsonsuk.co.uk

# options & specifications



For your piece of mind, Probe Technic Shelving has passed the following British Standards for strength and rigidity:  
**BS 4875-7: 2006 PART 7 & BS 4875-8: 1998 PART 8**

# options

## DOUBLE SIDED BAY



- FLUSH/CANOPY SHELF**
- DECOR END PANEL BRACKET**  
Placed at the top and bottom of the upright they provide fixings for the Decor End Panel.
- DISPLAY SHELF**
- TAPE CASSETTE SHELF**
- DVD/CD/VIDEO SHELF**
- STANDARD SHELF**

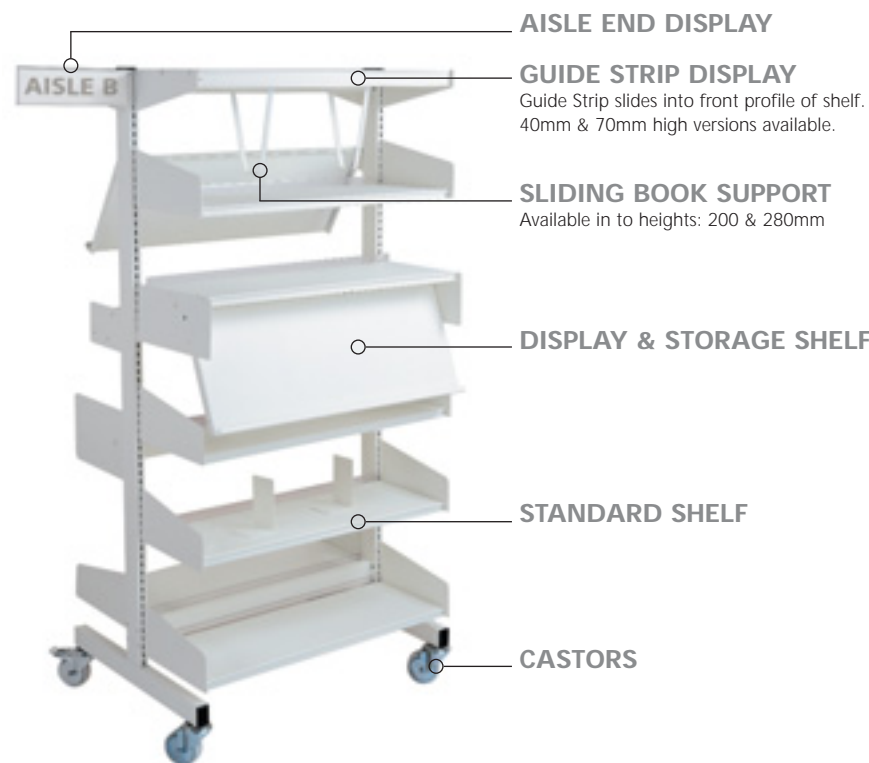

- AISLE END DISPLAY**
- GUIDE STRIP DISPLAY**  
Guide Strip slides into front profile of shelf. 40mm & 70mm high versions available.
- SLIDING BOOK SUPPORT**  
Available in to heights: 200 & 280mm
- DISPLAY & STORAGE SHELF**
- STANDARD SHELF**
- CASTORS**

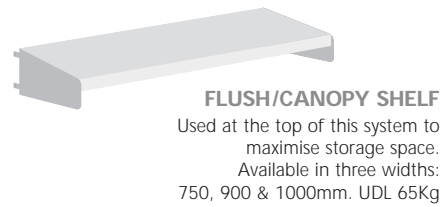

**FLUSH/CANOPY SHELF**  
Used at the top of this system to maximise storage space.  
Available in three widths: 750, 900 & 1000mm. UDL 65Kg



**DISPLAY & STORAGE SHELF**  
This shelf is similar to the display shelf with the added facility to store a number of displayed items.  
Available in three widths: 750, 900 & 1000mm. UDL 65Kg

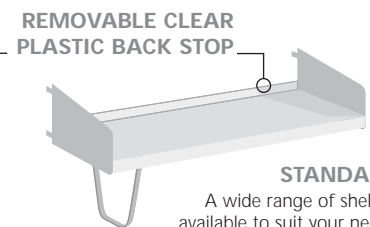

**STANDARD SHELF**  
A wide range of shelf options are available to suit your needs. Standard shelf comes with clear plastic back stop. Pictured with optional Sliding Book Support.  
Available in three widths: 750, 900 & 1000mm. UDL 65Kg



**DISPLAY SHELF**  
Display documents, brochures and products.  
Available in three widths: 750, 900 & 1000mm. UDL 65Kg



**TAPE/VIDEO CASSETTE OR CD/DVD SHELF**  
Width: 900mm. UDL 65Kg



**CONVERSION BRACKET**  
The conversion bracket can be used to adapt a standard shelf into a display shelf.

## WHEEL MOUNTED

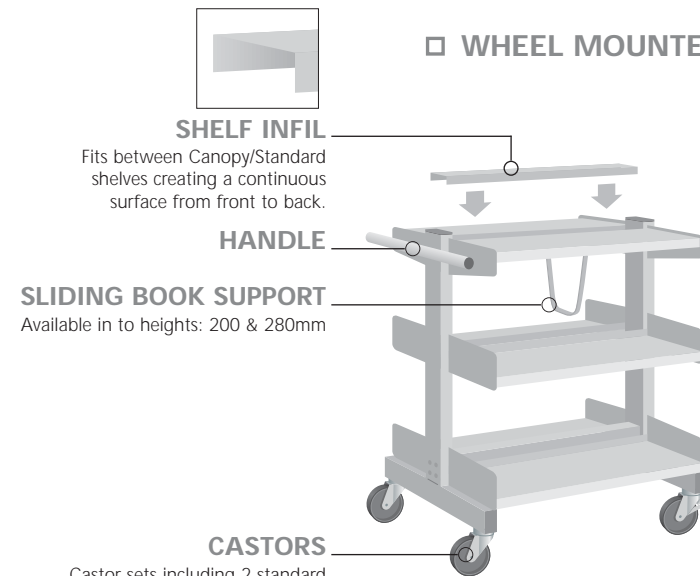

- SHELF INFIL**  
Fits between Canopy/Standard shelves creating a continuous surface from front to back.
- HANDLE**
- SLIDING BOOK SUPPORT**  
Available in to heights: 200 & 280mm
- CASTORS**  
Castor sets including 2 standard and 2 braked wheels are available, enabling the shelving to be moved easily.

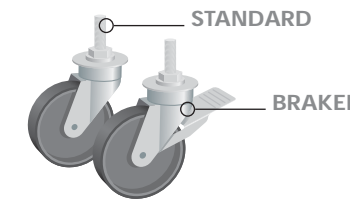

## WALL MOUNTED

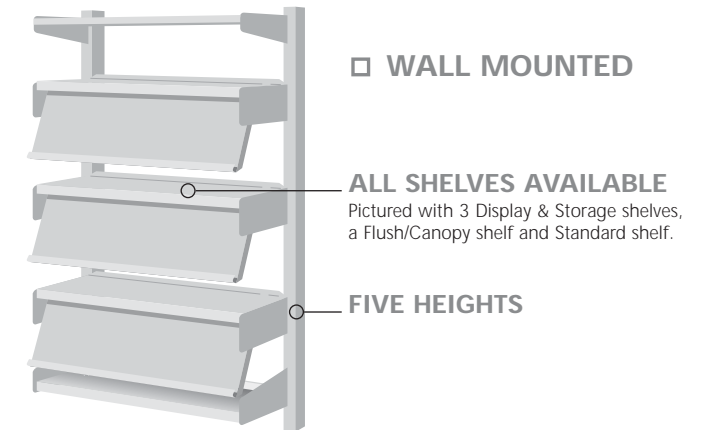

- ALL SHELVES AVAILABLE**  
Pictured with 3 Display & Storage shelves, a Flush/Canopy shelf and Standard shelf.
- FIVE HEIGHTS**

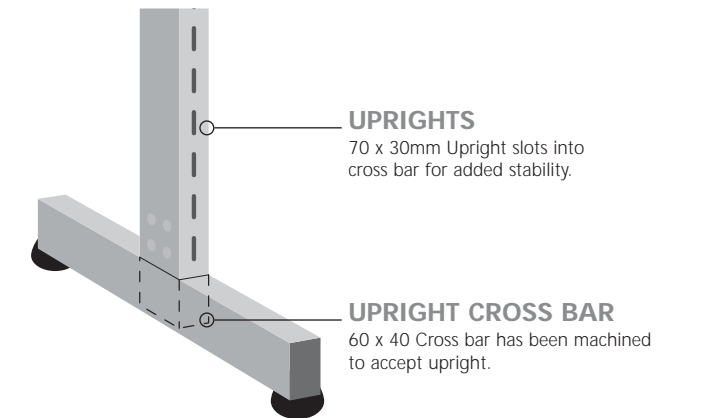

- UPRIGHTS**  
70 x 30mm Upright slots into cross bar for added stability.
- UPRIGHT CROSS BAR**  
60 x 40 Cross bar has been machined to accept upright.

**maximum bay loading 500kg**  
dependent on specification

MAXIMUM SHELF LOADING (UNIFORMLY DISTRIBUTED)		
SHELF	WIDTH(mm)	UDL
Flush/Canopy Shelf	750	65kg
	900	65kg
	1000	65kg
Shelf depths available: 200 250 300 350 (mm)		
Standard Shelf	750	65kg
	900	65kg
	1000	65kg
Shelf depths available: 200 250 300 350 (mm)		
Display Shelf	750 x 350	65kg
	900 x 350	65kg
	1000 x 350	65kg
Tape Cassette Shelf	900	65kg
Video or CD/DVD Shelf	900	65kg
Display & Storage Shelf	750 x 350	65kg
	900 x 350	65kg
	1000 x 350	65kg

## heights

### SINGLE & DOUBLE SIDED BAYS

HEIGHT (mm) UPRIGHTS	WIDTHS (mm) SHELF
1200	750
1500	
1800	
2100	
2300	

### WALL BARS

HEIGHT (mm) UPRIGHTS	WIDTHS (mm) SHELF
1030	750
1380	
1680	
2030	
2530	



6 Collingwood Court  
Riverside Park  
Middlesbrough TS2 1RP

**Tel: 01642 242228 | Fax: 01642 242259**  
**www.richardsonsuk.co.uk | sales@richardsonsuk.co.uk**